



MANIC DROPPER POST OWNER'S MANUAL



THE MANIC POST IS MARKED WITH A MINIMUM INSERTION LINE.

THIS IS THE MINIMUM AMOUNT OF INSERTION REQUIRED FOR THE POST TO REMAIN STRUCTURALLY SAFE.

ALSO, SOME FRAMES REQUIRE ADDITIONAL INSERTION TO ENSURE THAT THE FRAME REMAINS STRUCTURALLY SOUND.

PLEASE CHECK WITH THE BICYCLE MANUFACTURER FOR ADDITIONAL INFORMATION

ASSEMBLY INSTRUCTIONS

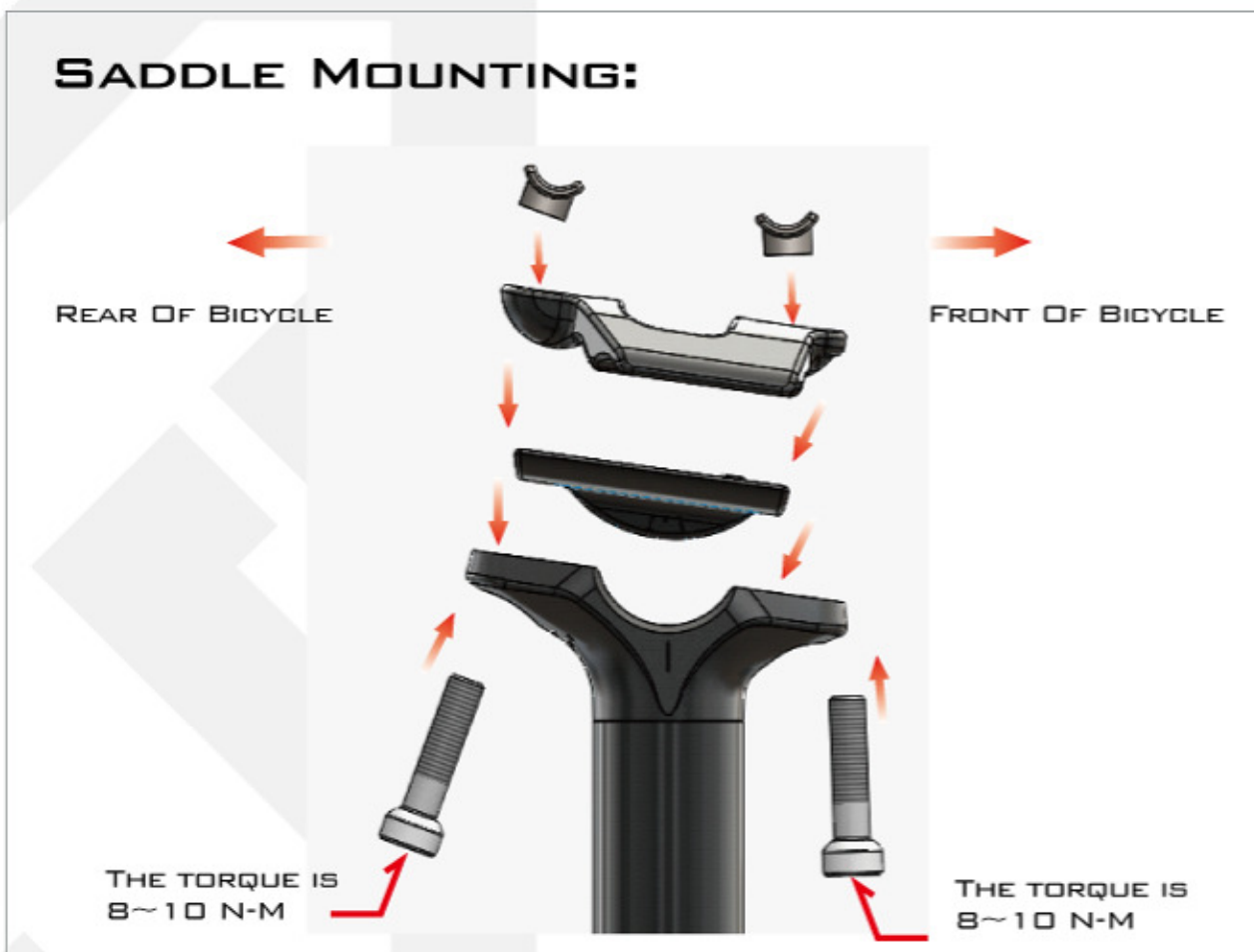

LEVER ANGLE ADJUSTMENT:

LOOSEN BOLT TO CHANGE LEVER ANGLE

MAXIMUM TORQUE
3.5 N-M

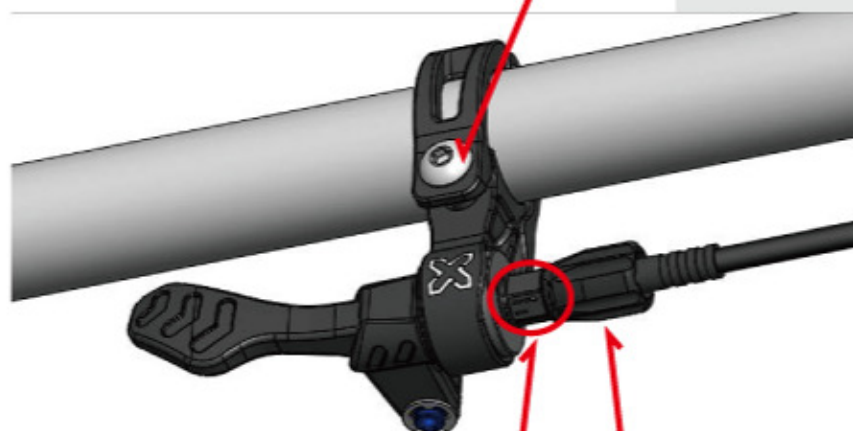

MAXIMUM TORQUE
3 N-M

TURN OUT TO ADJUST
CABLE TENSION

REMOTE LEVER

HOUSING

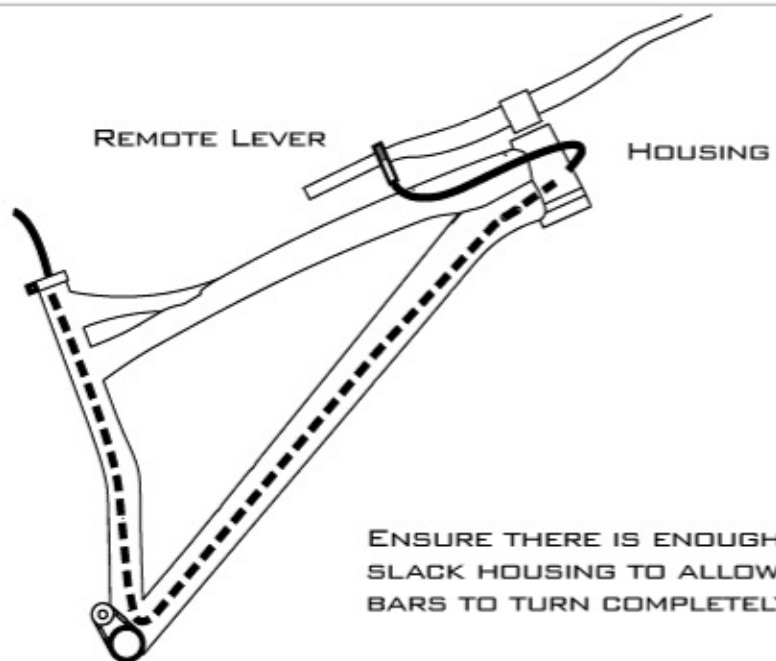

ENSURE THERE IS ENOUGH
SLACK HOUSING TO ALLOW
BARS TO TURN COMPLETELY

MAXIMUM
TORQUE
1.1 N-M

MAXIMUM
TORQUE
0.2 N-M



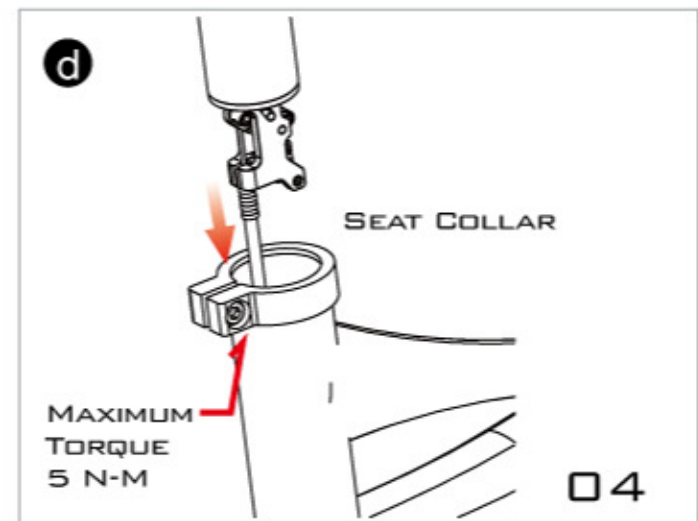
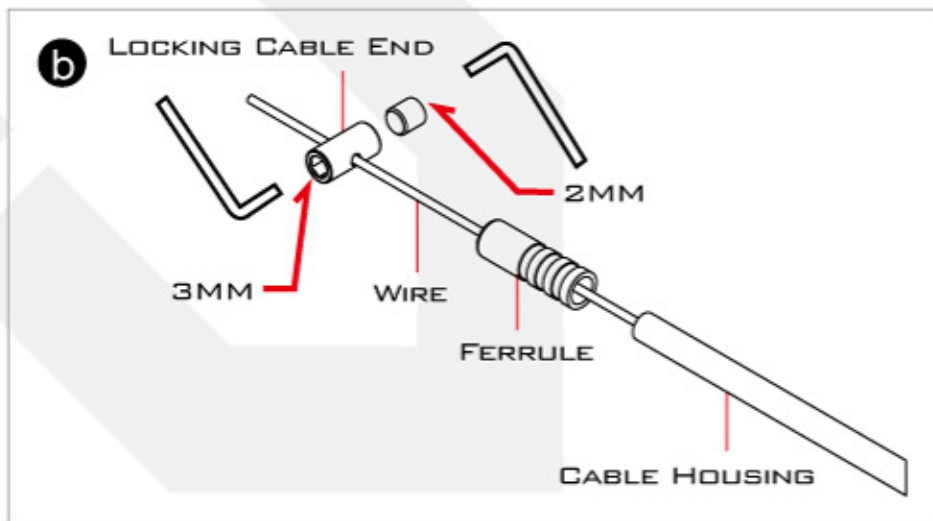
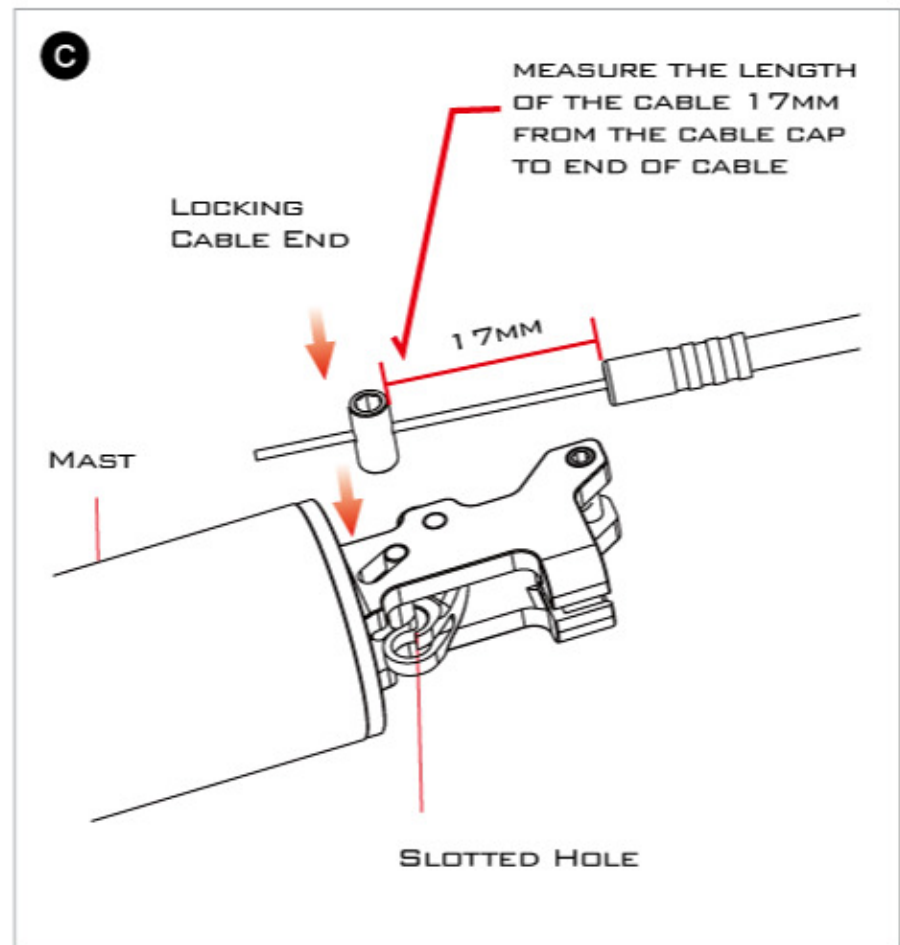
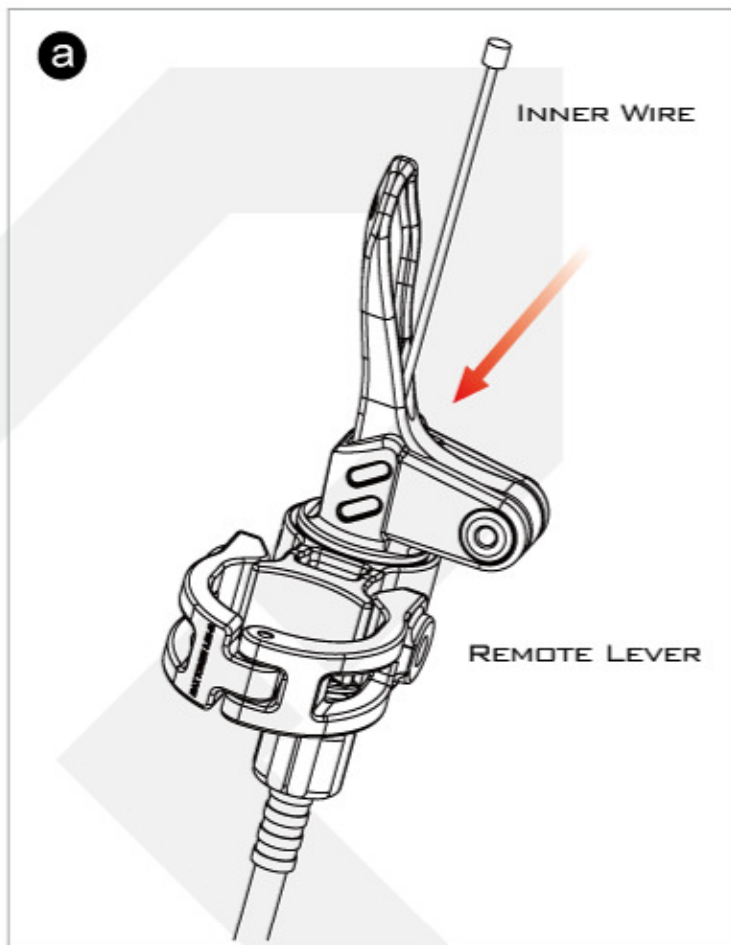

MANIC MAINTENANCE CYCLE

MANIC MAINTENANCE CYCLE	
CLEAN DEBRIS FROM SEAT POST	EVERY RIDE
LUBRICATE SEAL HEAD	EVERY MONTH
CLEAN AND LUBRICATE CABLE UNDER SADDLE	EVERY MONTH
REPLACE CABLE, HOUSING, SEAL	100 HOURS
REPLACE INNER CARTRIDGE	EVERY 12 MONTHS
FULL SERVICE	200 HOURS/ EVERY 12 MONTHS
REPLACE BRASS KEY WAY	AS NEEDED

WARNING

IMPORTANT INFORMATION

THIS INSTRUCTION GUIDE CONTAINS IMPORTANT SAFETY, PERFORMANCE AND SERVICE INFORMATION. READ IT BEFORE YOU TAKE THE FIRST RIDE ON YOUR NEW MANIC POST

THIS MANUAL IS NOT INTENDED AS A COMPREHENSIVE USE, SERVICE, REPAIR OR MAINTENANCE MANUAL. PLEASE CONTACT X-FUSION FOR SERVICE, REPAIRS OR MAINTENANCE.

BECAUSE IT IS IMPOSSIBLE TO ANTICIPATE EVERY SITUATION OR CONDITION THAT CAN OCCUR WHILE RIDING, THIS INSTRUCTION GUIDE MAKES NO REPRESENTATION ABOUT THE SAFE USE OF THE BICYCLE UNDER ALL CONDITIONS. THERE ARE RISKS ASSOCIATED WITH THE USE OF ANY BICYCLE THAT CANNOT BE PREDICTED OR AVOIDED, AND WHICH ARE THE SOLE RESPONSIBILITY OF THE RIDER.

• AN INCORRECT SIZING INTERFACE CAN RESULT IN SLIPPAGE AND/OR FAILURE OF THE MANIC POST, CAUSING SERIOUS PERSONAL INJURY OR DEATH. ENSURE YOUR SEAT TUBE IS MADE TO ACCEPT THE CORRECT SIZE POST BEFORE INSERTING INTO FRAME

• SEAT COLLAR TORQUE REQUIREMENTS CAN VARY DEPENDING ON THE FRAME AND SEAT COLLAR USED. EXCEEDING THE MAXIMUM TORQUE LIMIT CAN RESULT IN DAMAGE TO THE MANIC AND/OR FRAME AND ALSO HAMPER RETURN ACTION, WHICH CAN RESULT IN A LOSS OF CONTROL OF THE BICYCLE AND SERIOUS PERSONAL INJURY OR DEATH.

• THE MANIC IS MARKED WITH A MINIMUM INSERTION LINE. THIS IS THE MINIMUM AMOUNT OF INSERTION REQUIRED FOR THE MANIC POST TO REMAIN STRUCTURALLY SAFE. ALSO, SOME FRAMES REQUIRE ADDITIONAL INSERTION TO ENSURE THAT THE FRAME REMAINS STRUCTURALLY SOUND.

• RECOMMENDED TORQUES IN THIS INSTRUCTION GUIDE ARE SPECIFIED FOR YOUR MANIC POST. CONSULT YOUR BICYCLE OWNER'S MANUAL FOR RECOMMENDED TORQUE SPECIFICATIONS FOR OTHER PARTS. WHEN MATING PARTS, USE THE LOWER TORQUE RECOMMENDATION.

• MAKE SURE THE CABLE HOUSING IS KINK-FREE, AND THAT IT DOES NOT INTERFERE WITH ANY BICYCLE COMPONENTS OR CLOTHING, NOR INTERFERE WITH HANDLEBAR MOVEMENT.

NOTE

WHEN THE POST SITS FOR A PROLONGED PERIOD OF TIME, OR THE FIRST TIME IT IS USED, IT MAY REQUIRE A HARD DOWNWARD MOVEMENT TO CYCLE THE POST THE FIRST TIME. THIS BREAKAWAY FORCE WILL DECREASE AS THE POST IS CYCLED, OR BE ELIMINATED COMPLETELY.

IF THE BREAKAWAY FRICTION IS EXCESSIVE, OR DOES NOT DECREASE ONCE SEATPOST IS CYCLED, CLEANING AND LUBRICATION OF THE SEATPOST MAY BE REQUIRED

 **FUSION**

WWW.XFUSIONSHOX.COM